

# User's Manual

## ——Semi-Automatic Asphalt Distributor Truck





# Contents

|  |    |
|--|----|
| Introduction .....   | 2  |
| Side view of standard asphalt distributor truck .....                    | 4  |
| II. Construction and Operation of Asphalt Distributor Truck System ..... | 5  |
| (I) Asphalt Tank .....   | 5  |
| (II) Power Train .....   | 6  |
| (III) Asphalt Pump and Piping .....                                      | 6  |
| (IV) Asphalt Heating System .....  | 7  |
| (V) Asphalt Pipe Cleaning System .....                                   | 8  |
| (VI) Electrical Control System .....                                     | 9  |
| III. Use and Operation of Asphalt Distributor Truck .....                | 10 |
| (I) Preparations of Operation .....                                      | 10 |
| (II) Asphalt Filling .....   | 10 |
| (III) Operation of Asphalt Transport .....                               | 13 |
| (IV) Operation of Asphalt Heating .....                                  | 13 |
| (V) Spraying of Asphalt .....  | 15 |
| (VI) Operation of Asphalt Pump and Pipe Cleaning .....                   | 18 |
| (VII) Completion of Construction .....                                   | 20 |
| IV. Technical Maintenance and Lubrication .....                          | 21 |
| V. Troubleshooting .....   | 23 |

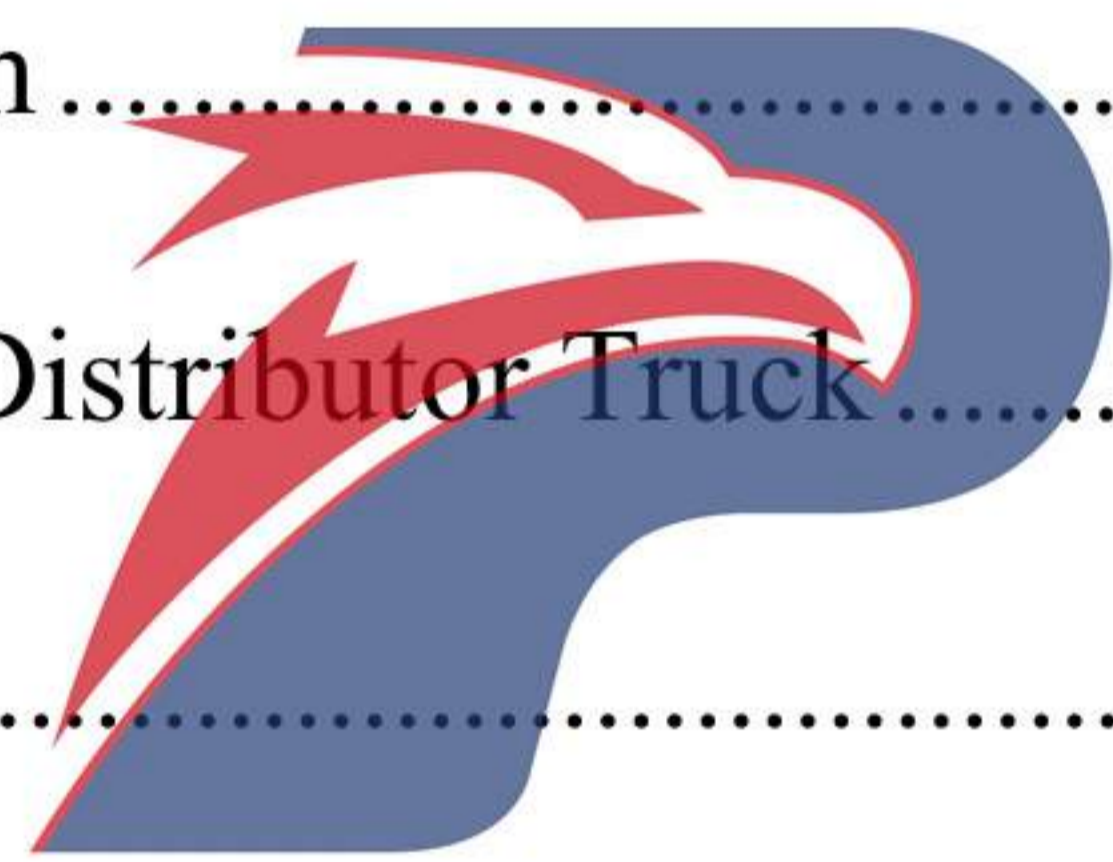

**POWERSTAR**



# Introduction

Standard Asphalt Distributor Truck is a machine specially designed for construction and curing of asphalt road surfaces, which is widely applied in operation, such as transport and distribution of high-temperature liquid asphalt, emulsified asphalt and modified asphalt. PowerStar's standard asphalt distributor truck uses Class II vehicle chassis equipped with an asphalt distributor which is finely developed by PowerStar.

The asphalt tank is covered with stainless steel sheets and is good in appearance. It has a good heat-insulating property due to application of aluminum silicate heat insulating material. The operation of the asphalt pump is controlled by hydraulic system and the transmission is stable, enabling safe and reliable operation. Asphalt can be sprayed evenly via the rear spray bar or the handheld spray bar according to the actual construction. The asphalt pump and piping can be cleaned by using diesel or compressed air, in order to ensure that no blockage exists in the pipes and nozzles. The maximum spray width is up to 6m, and the spraying operation is high-efficiency and easy, with safe and reliable service behavior.

This manual will provide the precautions, specifications, basic principle of operation, operation instructions and troubleshooting for the standard asphalt distributor truck. For normal operation of the asphalt distributor truck and high cost efficiency, please carefully read this manual before using this asphalt distributor truck for the first time, and use, maintain and service it in exact accordance with the manual. For any question, please contact our after-sales service department, and we will gladly assist you. For use, maintenance and service of the chassis, refer to the attached "User's Manual" from the original manufacturer. Please carefully read it as well before using this asphalt distributor truck, and always operate and service truck in exact accordance with the manual.

This manual is subject to change without further notice. Please understand the items included may change and the actual product may vary.





## Precautions

1. Owing to the very high surface temperature of the operating devices and pipes of the asphalt distributor truck during operation, please wear work clothes, gloves and helmet before working to avoid scalding.
2. For the first time a new truck is used, the amount of asphalt filled shall be less than 60% of the rated tank volume.
3. To fill hot asphalt, it is required to drain off water remained in the tank; otherwise, the hot asphalt may sharp expand and spray out when it meets cold water, which may result in a danger.
4. To change the material from emulsified asphalt to hot asphalt, the emulsified asphalt inside the tank must be removed completely; otherwise a danger may take place.
5. During the course of transporting and spraying, it's prohibited absolutely to allow people standing on the rear working platform of the asphalt distributor truck.
6. Once the vehicle is filled with hot asphalt, personnel other than those associated with operation shall be kept at least 5m away from the asphalt distributor truck for safety.
7. To ensure satisfactory spraying quality, for common roads with a heavy traffic, the temperature of asphalt shall be higher than 160°C, higher than 185°C for SBS and SBR modified hot asphalt, and within the range from 65 to 85°C for SBS and SBR modified asphalt emulsion.
8. When emulsified asphalt is used, the bottom settlements of large storage tank shall not be filled into the asphalt distributor truck, or failure will result.
9. The asphalt pump seized must not be started up by force, and it cannot run before it is heated for slackness.
10. To change the material from hot asphalt to emulsified asphalt, the residual asphalt inside the asphalt pump, pipes, and tank must be removed completely so as not to lead to failure of operation.
11. Before shifting the power take-off, disengage the clutch first. Otherwise, the power take-off or truck transmission will be damaged.
12. The gearbox should be shifted to a higher gear during transportation and to a lower gear during spraying. Always disengage the clutch and then shift when the truck runs at low speed or is stopped.
13. The asphalt distributor truck shall be transported with the power take-off disengaged, the burner off and asphalt inlet and outlet valves closed.
14. The asphalt pump and pipes must be purged when a tank of asphalt is depleted.
15. After daily work, always drain off the asphalt remained in the tank.





Side view of standard asphalt distributor truck



Rear view of standard asphalt distributor truck



# I. Construction and Operation of Asphalt Distributor Truck System

Standard asphalt distributor truck consists of truck chassis, asphalt tank, power train, asphalt pump, piping, asphalt heating system and pipe cleaning system.

## (I) Asphalt Tank

The asphalt tank (as shown in Fig. 1) consists of inner tank, insulating materials, casing, baffle, combustion chamber, in-tank pipes, side box, air reservoir, oil filler, volume meter, and trim plate. The tank body is an elliptical cylinder which is constructed with inner and outer steel plates welded together and filled with aluminum silicate heat-insulating materials in between. It is 50 mm in thickness, and is equipped with a sink duct at the bottom which facilitates sucking all asphalt in the tank. At the bottom of the tank, five mounting legs and an auxiliary beam are welded into a single unit that is fixed to the truck frame. The volume meter is used to indicate the level of asphalt in the tank. The oil filler is composed of two parts. The underneath cover should be opened when required to enter the tank for service, only the cap is opened usually for asphalt filling.

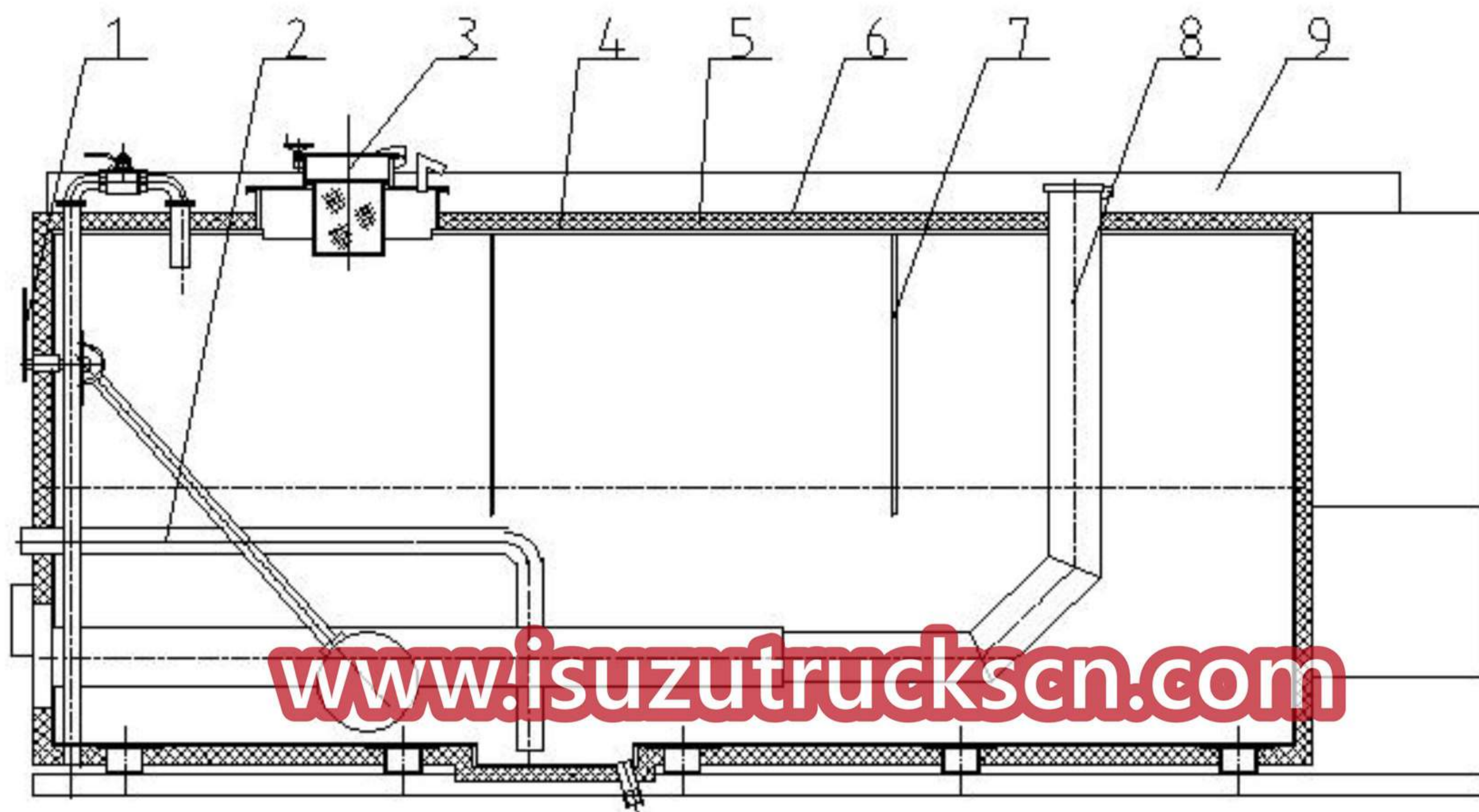

Fig. 1 Asphalt tank

1. Volume meter 2. Oil sucking pipe 3. Oil filter 4. Inner tank 5. Heat insulating material

6. Casing 7. Baffle 8. Combustion chamber 9. Trim plate



## (II) Power Train

The power train consists of power take-off and pump transmission. The power take-off is a mechanical gearbox structure with two shafts. The input gear is engaged with the 3<sup>rd</sup> gear of intermediate shaft of the truck transmission and the output shaft outputs the power. The shift fork will be driven by compressed air to achieve gear engagement or disengagement by engaging gear sleeve. The pump transmission consists of flange, universal drive shaft, and hydraulic pump mounting base, which transmits the power from the power take-off to the hydraulic pump.

The hydraulic system (as shown in Fig. 2) consists of hydraulic pump, overflow valve, reversal valve, hydraulic motor, and hydraulic pipes, which transmits the power from the hydraulic pump to the asphalt pump through the hydraulic motor.

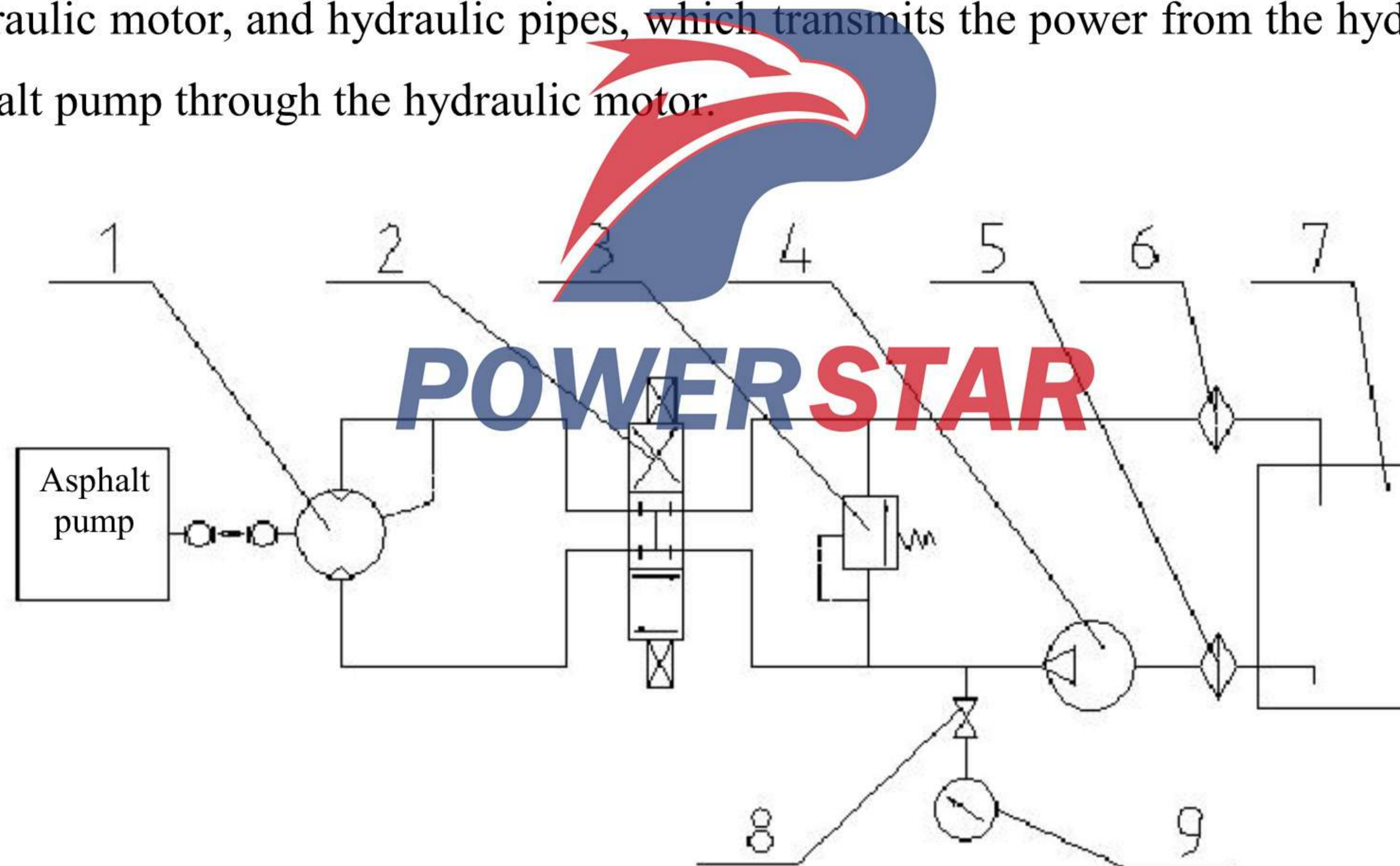

Fig. 2 Hydraulic system

1. Plunger motor
2. Reversal valve
3. Overflow valve
4. Gear pump
5. Suction filter
6. Return line filter
7. Hydraulic oil tank
8. Pressure gauge switch
9. Pressure gauge

## (III) Asphalt Pump and Piping

The asphalt pump and piping (as shown in Fig. 3) consists of asphalt pump, filter, valves, spraying pipes, and nozzles. They are mainly used to fill asphalt by self-suction, and to spray asphalt via rear spray bar or handheld spray bar.



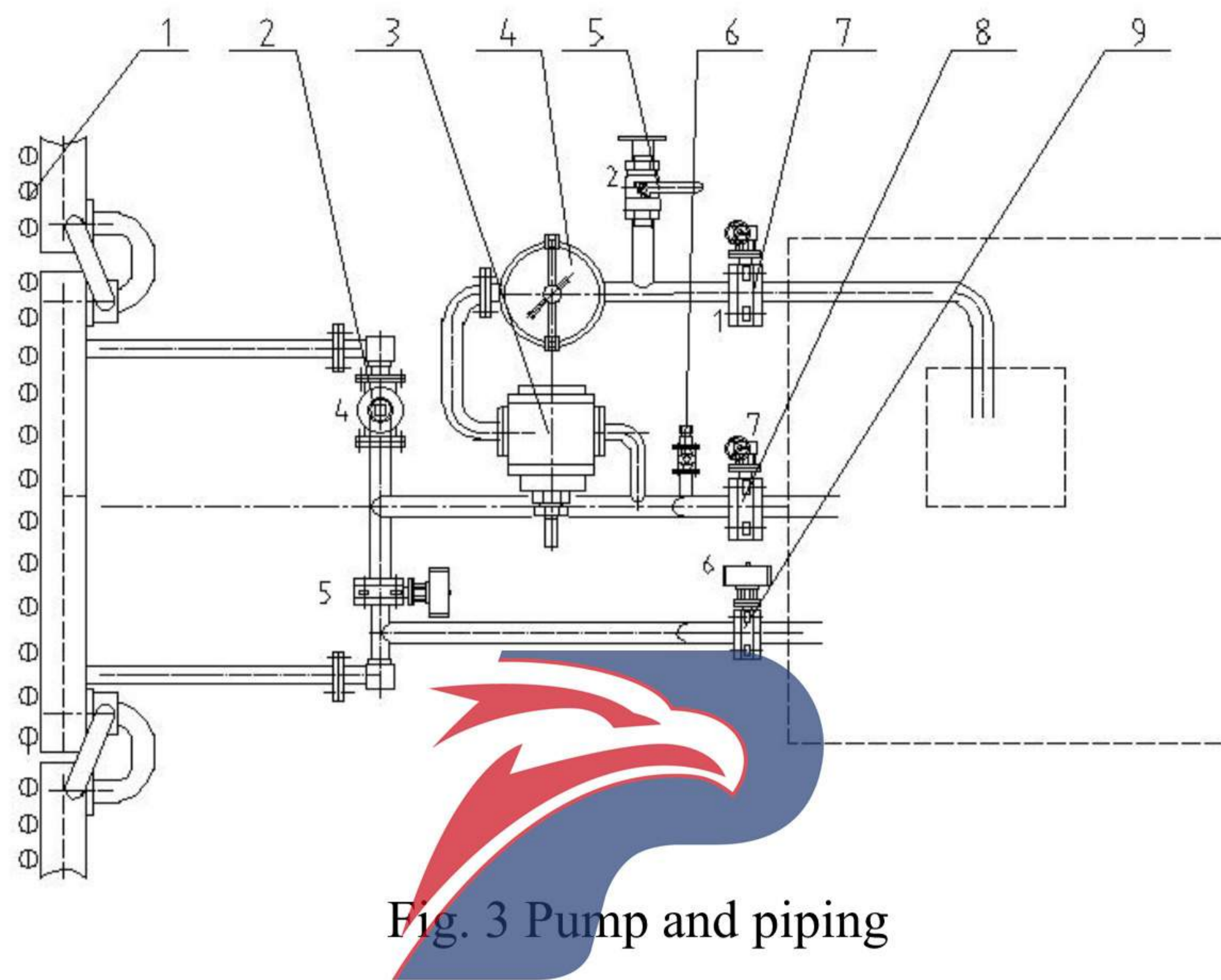

Fig. 3 Pump and piping

1. Nozzle 2. Oil outlet valve 3. Asphalt pump 4. Filter 5. Self-suction valve 6. Handheld spray bar valve  
 7. Oil inlet valve 8. Manual oil return valve 9. Pneumatic oil return valve

#### (IV) Asphalt Heating System

The asphalt heating system (as shown in Fig. 4) consists of combustion chamber, fuel tank, fuel valve, burner, air compressor and air valve. The diesel supplied to the burner via the fuel valve is mixed and atomized with the compressed air from the air reservoir. The waste gas is exhausted from the flue. The heat around the combustion chamber can heat the asphalt inside the tank. The size and temperature of flame can be regulated via the copper ball valve and air valve. The truck is equipped with two burners.

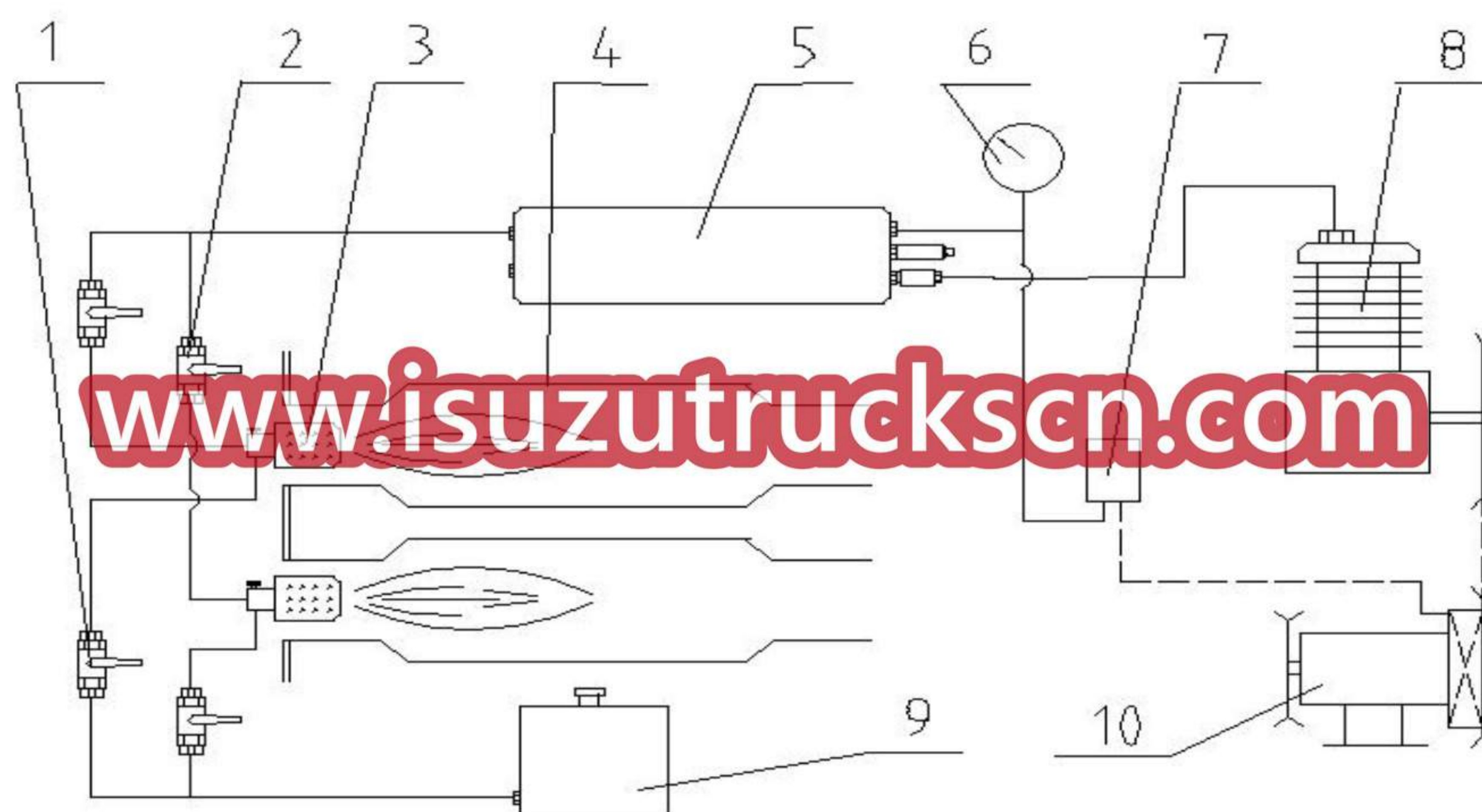

Fig. 4 Asphalt heating system

1. Fuel valve 2. Air valve 3. Burner 4. Combustion chamber 5. Air reservoir 6. Air pressure gauge  
 8. Pressure regulation switch 8. Air compressor 9. Oil tank 10. Electromagnetic clutch



## (V) Asphalt Pipe Cleaning System

The pipe cleaning system (as shown in Fig. 5) includes the diesel cleaning and compressed air flushing parts. The diesel cleaning part consists of diesel tank, copper ball valves and pipes. The compressed air flushing part is composed of an air reservoir, check valve and air valve. The asphalt pump runs at a low speed and the diesel is circulated to be cleaned from the valve via the filter and asphalt pump, to diesel tank. Close the diesel valve and open the air valve. The compressed air will flow from the valve, via the filter, asphalt pump and rear spray bar, to the nozzle, purging out the asphalt and the diesel remained in the pipe from the nozzle. The check valve can prevent the asphalt from returning to the air reservoir.

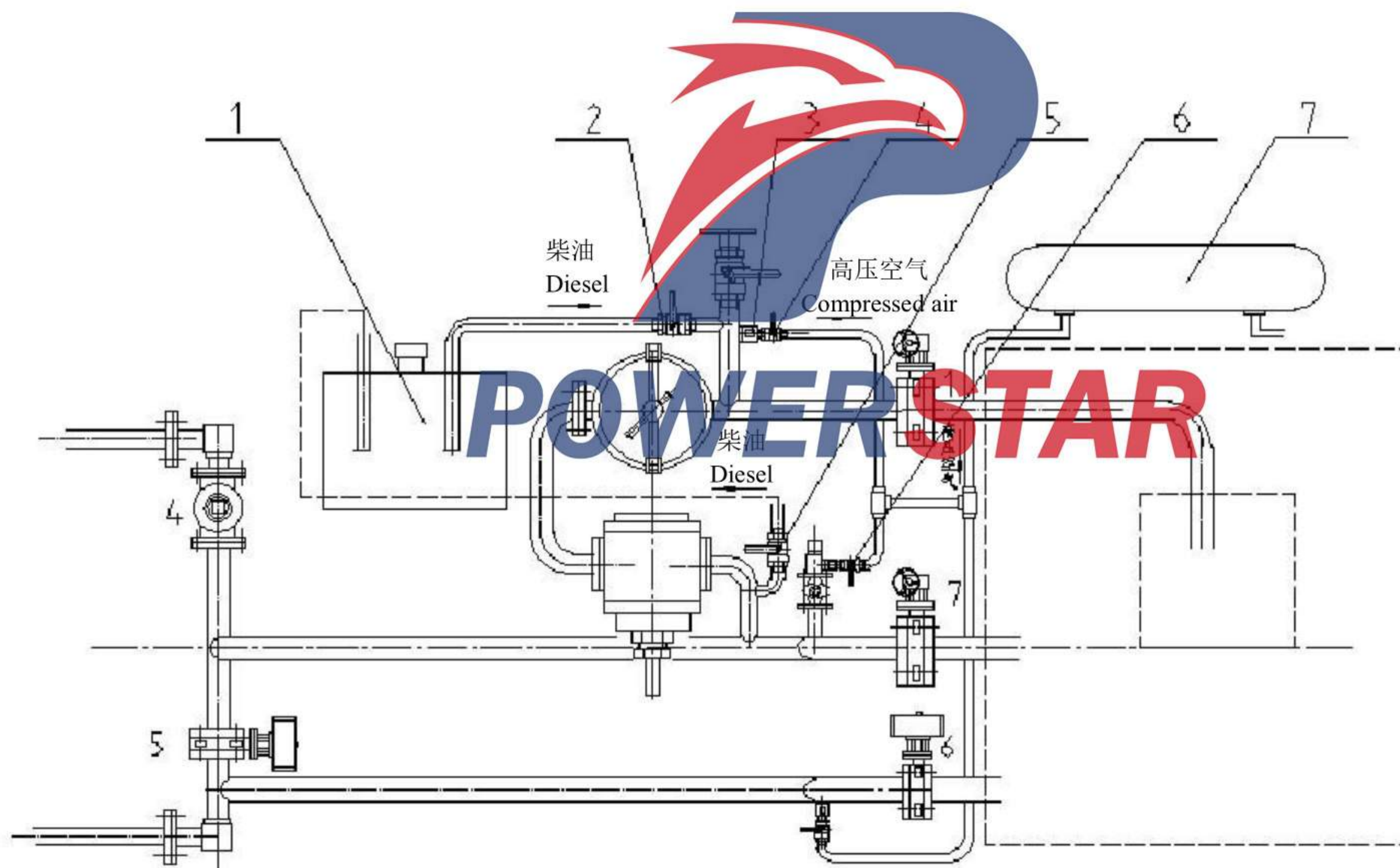

Fig. 5 Pipe cleaning system

1. Cleaning oil tank
2. Oil inlet copper ball valve
3. Air check valve
4. Main pipe air valve
5. Oil return copper ball valve
6. Air reservoir
7. Handheld spray bar air valve



## (VI) Electrical Control System

The electrical control system (as shown in Fig. 6) can be controlled via either the cab or the rear console. It consists of gearbox and power take-off control circuit, hydraulic reversal valve and asphalt control valve circuits, and rear working light.

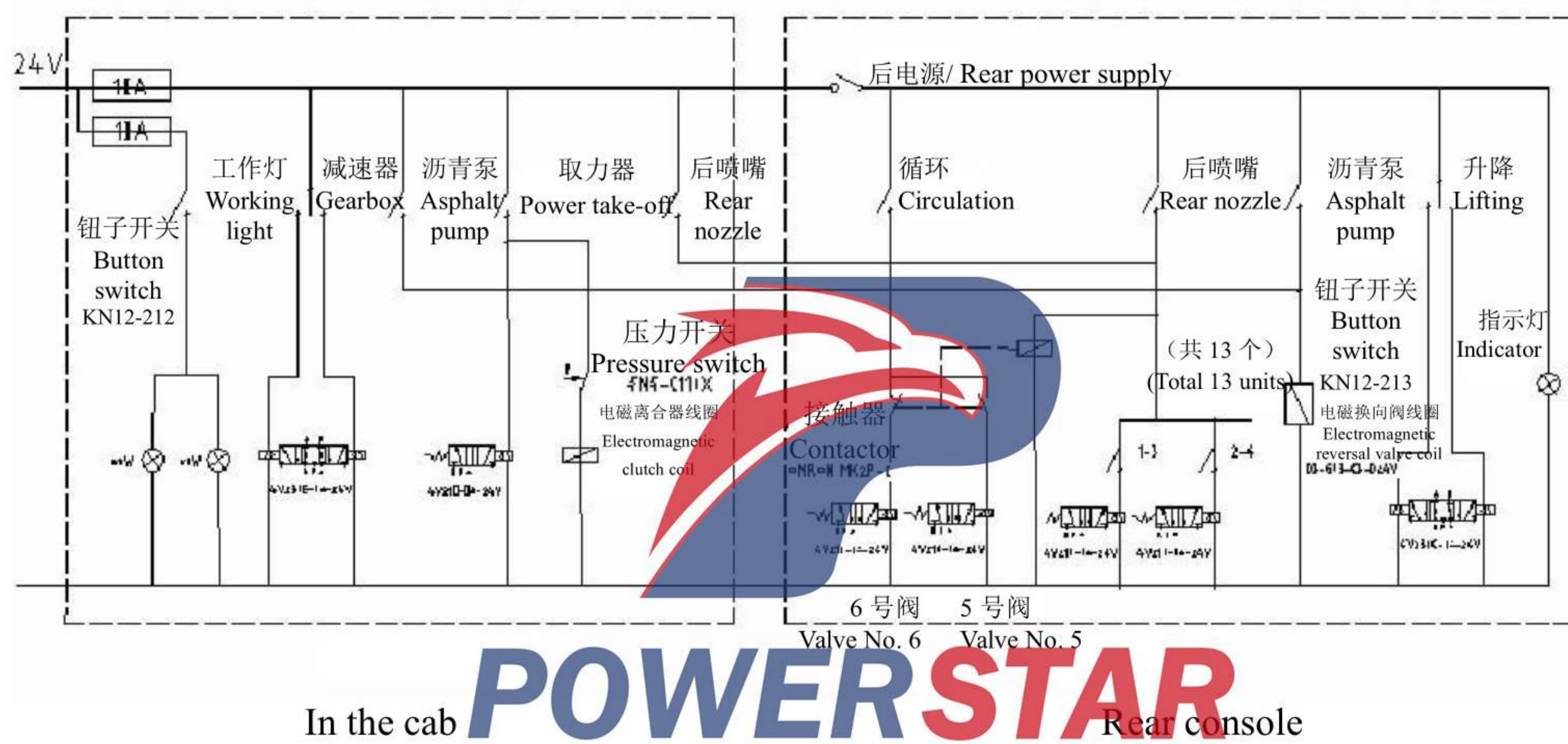

Fig. 6 Electrical control system



## II. Use and Operation of Asphalt Distributor Truck

Using the asphalt distributor truck correctly and observing regulations associated with operation can give full play of the mechanical efficiency, keep the machinery in good condition, thus improving the productivity and reducing the construction cost. Use and operate the asphalt distributor truck according to the operation processes below.



Operation flow chart of the asphalt distributor truck

### (I) Preparations of Operation

Carefully check the items below and ensure that there is no fault before filling asphalt into the tank.

1. Check the steering, braking, electrical and traveling devices of the vehicle for normal and reliable operation.
2. Check that the engine lubricating oil, fuel and cooling water are enough and that there is no leakage.
3. Fill appropriate quantity of diesel (approx. 35L) into the diesel cleaning tank.
4. Close all valves of piping, especially the diesel inlet and oil return copper ball valves and air valve; otherwise, asphalt may be returned to the air reservoir or the diesel tank, thus causing a fault).
5. Check that the rear spray bar or the handheld spray bar and the nozzles are unblocked, and that the asphalt pump can run normally.
6. Put the transmission and power take-off into the neutral position before starting the engine.
7. Start the engine and shift the power take-off, and check the hydraulic system and all the electrical switches for normal operation.
8. Turn the waste gas valve to the insulation position (i.e. the lower position).

### (II) Asphalt Filling

The asphalt can be filled by two methods, that is, either from an **off-vehicle equipment** or by



## self-suction of the asphalt pump.

### Method 1: Filling asphalt from an off-vehicle equipment

After verifying that no failure exists, drive the distributor truck to the position under the filling pipe. Close all valves first, open the oil filler cap on top of the tank (as shown in Fig. 7), and insert the oil filling pipe to start filling asphalt. After filling, securely tighten the oil filler cap.

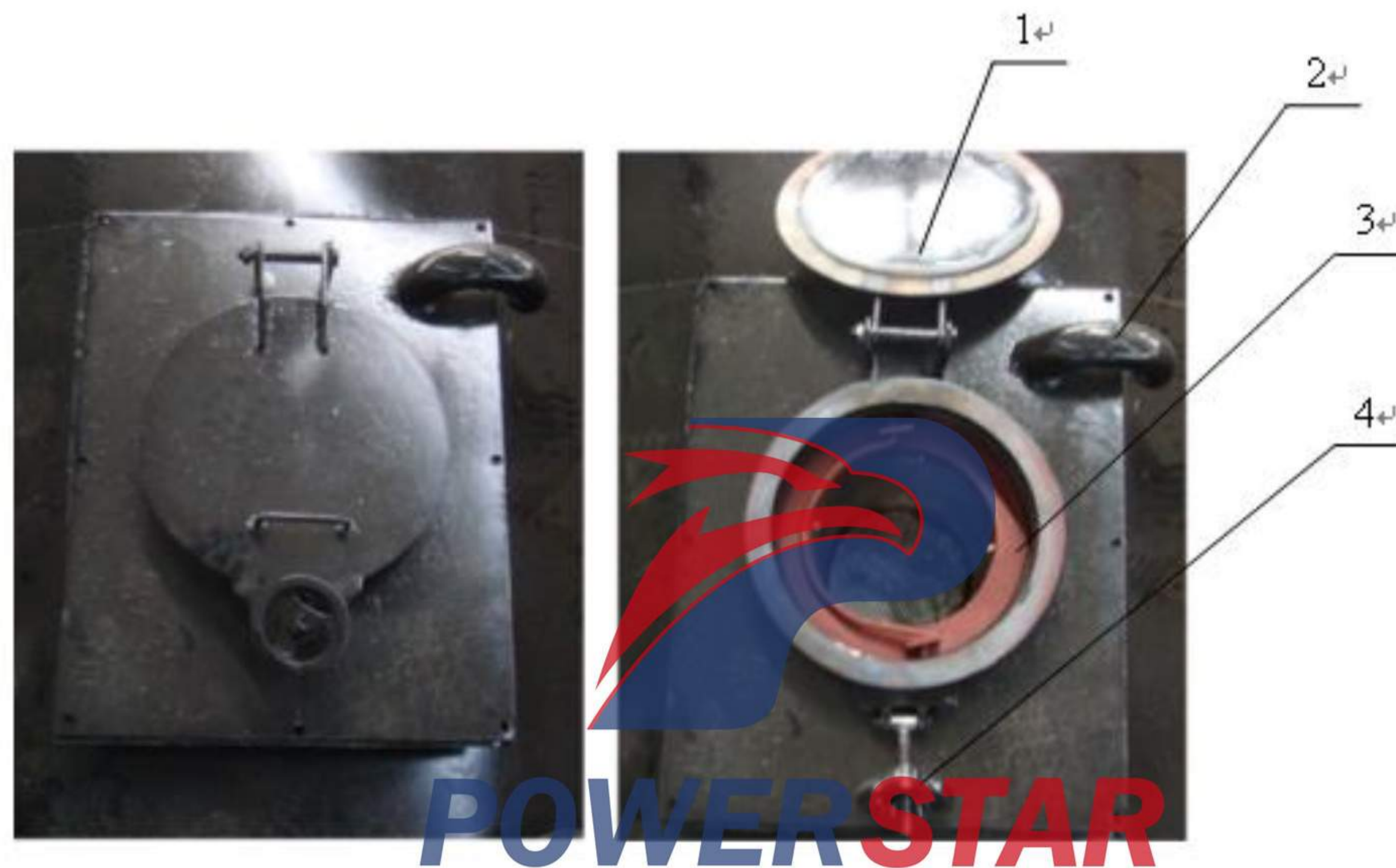

Fig. 7 Asphalt tank oil filler

1. Oil filler cap 2. Breather 3. Strainer 4. Locking device

### Pay attention to the following when filling asphalt:

1. Never fill the asphalt tank excessively, especially for hot asphalt, so as to avoid an overflow.
2. The filled asphalt must reach the following temperature. If the heating duration is too long that will cause adverse effect on the service life and the efficiency of the equipment. For common roads with a heavy traffic, the temperature of hot asphalt shall be higher than 160°C, higher than 185°C for SBS and SBR modified hot asphalt, and within the range of 65-85°C for SBS and SBR modified asphalt emulsion.
3. For the first time a new truck is used, drain off the water accumulated in the tank to avoid an accident, and the amount of asphalt filled shall be less than 60% of the tank volume.
4. After emulsified asphalt is used, make sure to drain off the remaining emulsified asphalt thoroughly before filling hot asphalt; otherwise, danger will be caused.
5. Regularly check if the breather is unblocked.



**Method 2:** Filling asphalt by self-suction of on-vehicle asphalt sucking pump

Drive the distributor truck to a place near the asphalt storage tank (within 5 meters), and securely connect the self-suction hose as shown in Fig. 8. Insert the hose to the tank, close the oil inlet valve 3 and oil outlet valve 4 (located at lower left corner of the rear platform), and open the self-suction valve 2 and oil return valve 5. Start the truck engine, shift the power take-off, and turn on the asphalt pump switch on the rear console and the asphalt pump switch as shown in Fig. 9. The engine speed shall be held at 2000 rpm.

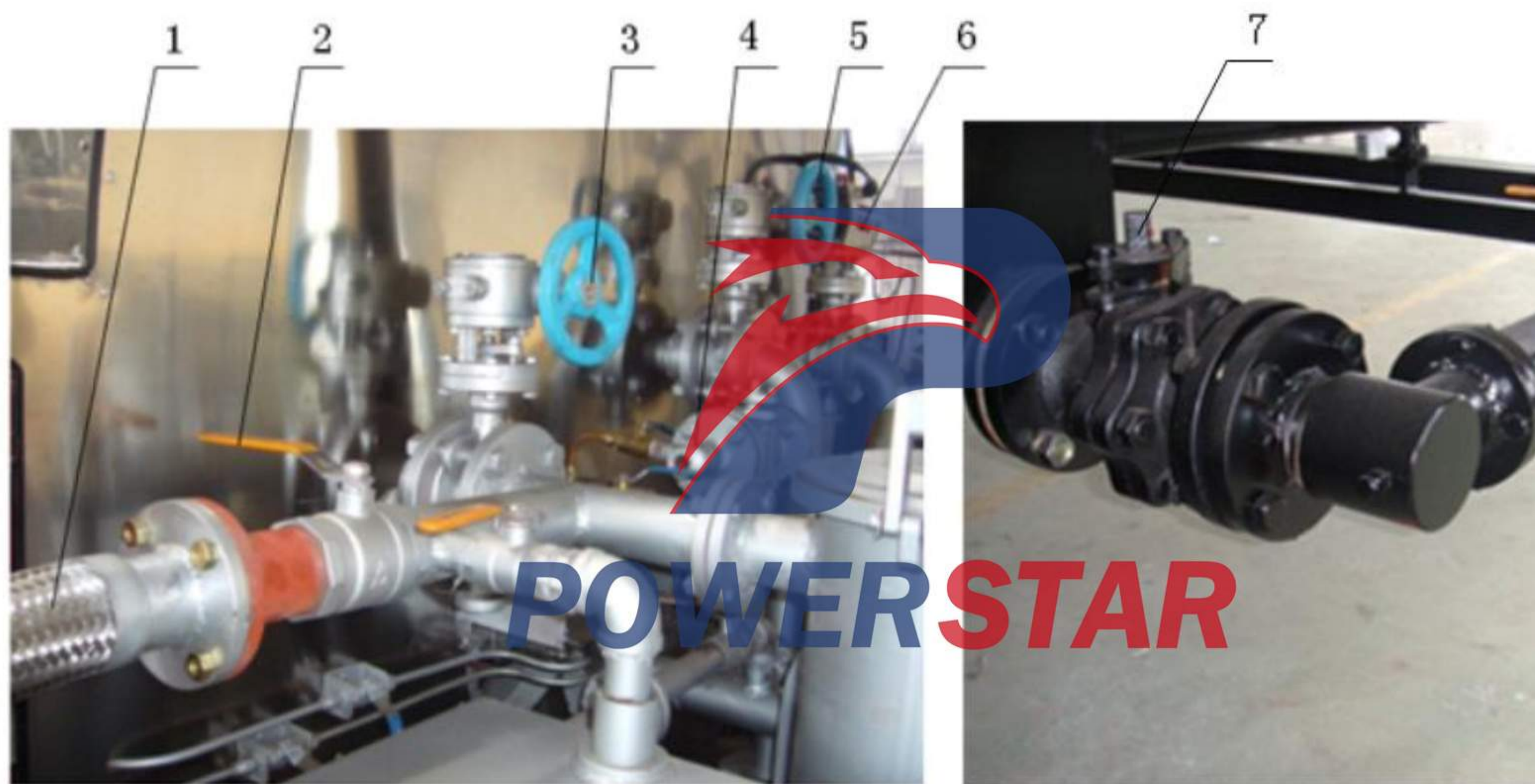
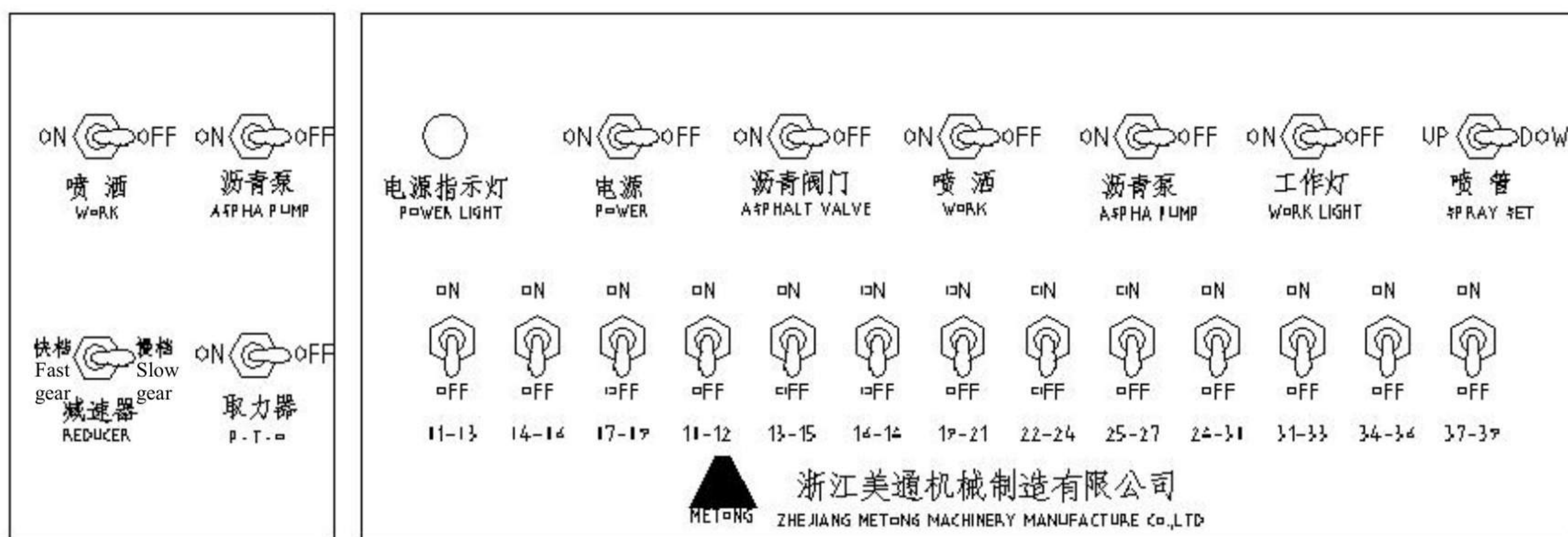

Fig. 8 Operation valve for self-suction

1. Self-suction hose 2. Self-suction valve 3. Oil inlet valve 4. Handheld spray bar valve  
 5. Manual oil return valve 6. Pneumatic oil return valve 7. Oil outlet valve  
 (located at lower left corner of the rear platform)



In the cab

Rear console panel

Fig. 9 Front and rear control switches



**⚠ Pay attention to the following when filling asphalt:**

1. The self-suction hose must be tightly connected, and the cap of the asphalt filter must be tightly compressed to prevent air leakage. The diesel cleaning valve and air valve must be tightly closed; otherwise, they cannot work.
2. Make sure that the asphalt level of the storage tank is higher than the center of the asphalt pump, with a distance less than 5 meters.

Other precautions are the same as those for Method 1.

**Since the asphalt pump works under high temperature, the inner clearance is fairly large. Long self-suction will result in quick abrasion. Therefore, Metong recommends minimizing the use of Method 2.**

### **(III) Operation of Asphalt Transport**



**POWERSTAR**

After the asphalt distributor truck has been filled up, truck clutch should be released and the gearbox should be engaged to the high speed gear (transportation gear). Then the truck should start slowly and runs to the site with the medium speed kept.

**⚠ Pay attention to the following when transporting asphalt:**

1. **Persons are absolutely prohibited to stand** in the rear operation platform during transportation.
2. The power take-off must be in neutral position, and **use of the burner is absolutely prohibited** during traveling.
3. Close all valves. Turn the waste gas valve to the insulation position (i.e. the lower position).
4. Minimize the use of high speed driving and emergency braking.

### **(IV) Operation of Asphalt Heating**

The asphalt filled into the tank after transported to the site must be heated up if its temperature does not meet the requirement for distributing operation and the method is as follows:



1. Park the distributor truck at a flat, level surface, idle the truck transmission, and start the truck engine. After that, shift the power take-off, and enable the air compressor to supply air. The engine speed shall be held at approx. 2000 rpm.
2. Open the funnel cover on top of the tank.
3. Prepare a torch, and dip it with diesel to ignite when the air pressure reaches 0.4 MPa.
4. Loosen the air knob on the burner (as shown in Fig. 10), and open the fuel valve. After that, open the air valve, and apply the fire near the burner to ignite when white smoke is found.
5. Adjust the air knob on the burner and the opening of fuel valve, until there is no black smoke from the funnel is found. The engine speed shall be held at approx. 1500 rpm.
6. After heating, close the fuel valve first, and then close the air valve.

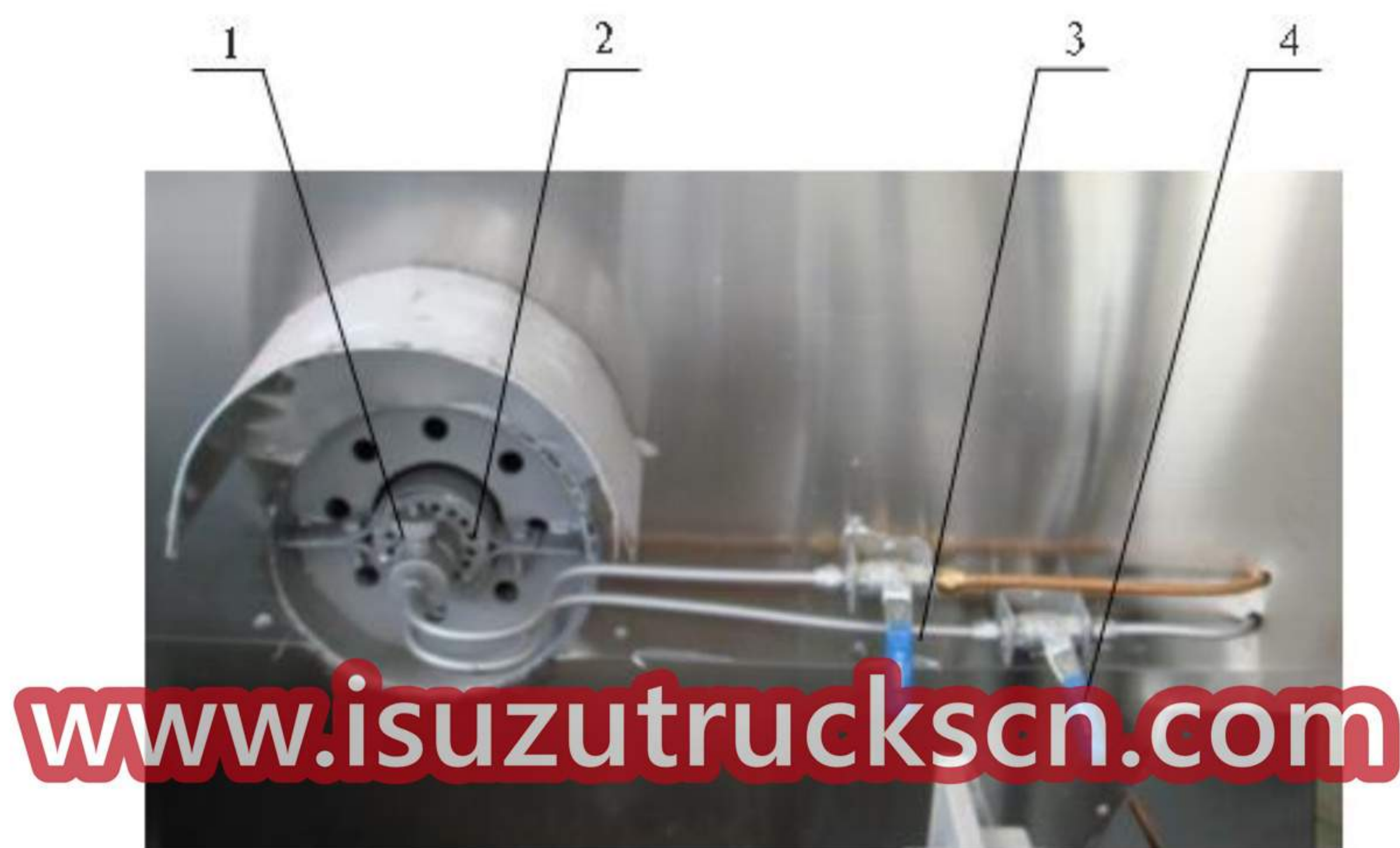

Fig. 10 Asphalt heater

1. Air knob 2. Burner 3. Air valve 4. Fuel valve

During asphalt heating, rotate the asphalt pump so that the asphalt inside the tank can be evenly heated.

Operation: Open the oil inlet valve (as shown in Fig. 9), close the two oil outlet valves, and open the oil return valve on top of the tank to circulate the asphalt from the tank via oil inlet valve, filter, asphalt pump and oil return valve to the tank.



**⚠ Pay attention to the following when heating the asphalt:**

1. The diesel shall be clean. **Never use gasoline or kerosene.**
2. After the ignition of the burner, the operator shall not leave the distributor truck to prevent the burner against self-extinguishment.
3. If the burner is self extinguishes, do not ignite immediately. In this case, close the fuel valve and open the air valve, in order to apply compressed air to remove the remained oil and gas (until no white smoke from the funnel is found).
4. Reignite by following the method mentioned.
5. Due to small power of distributor truck burner, the burner can only be used for thermal insulation and small temperature rise, which is not applicable to achieve high temperature rise. It shall not be used as an oil melting stove.
6. Do not use the asphalt when the asphalt level in the tank is lower than the combustion chamber.

### **(V) Spraying of Asphalt**

After the temperature of asphalt inside the tank meets the spraying requirements, drive the asphalt distributor truck to the worksite and stop it stably about 10 meters away from the starting point of operation. According to the construction requirements, the operator can spray asphalt via automatic spray by front console, manual spray by rear console, or handheld spray bar. The detailed operation is as follows:

#### **Automatic spray via rear spray bar by front console:**

1. Level the left and right spray bars, and lower the rear spray bar by using the lifting switch (as shown in Fig. 9) so that the nozzle is about 250 mm away from the ground. The height could be adjusted with the chain.
2. Open the oil inlet valve (as shown in Fig. 11) and the oil outlet valve (located at the lower left corner of the rear platform), and close the manual oil return valve.



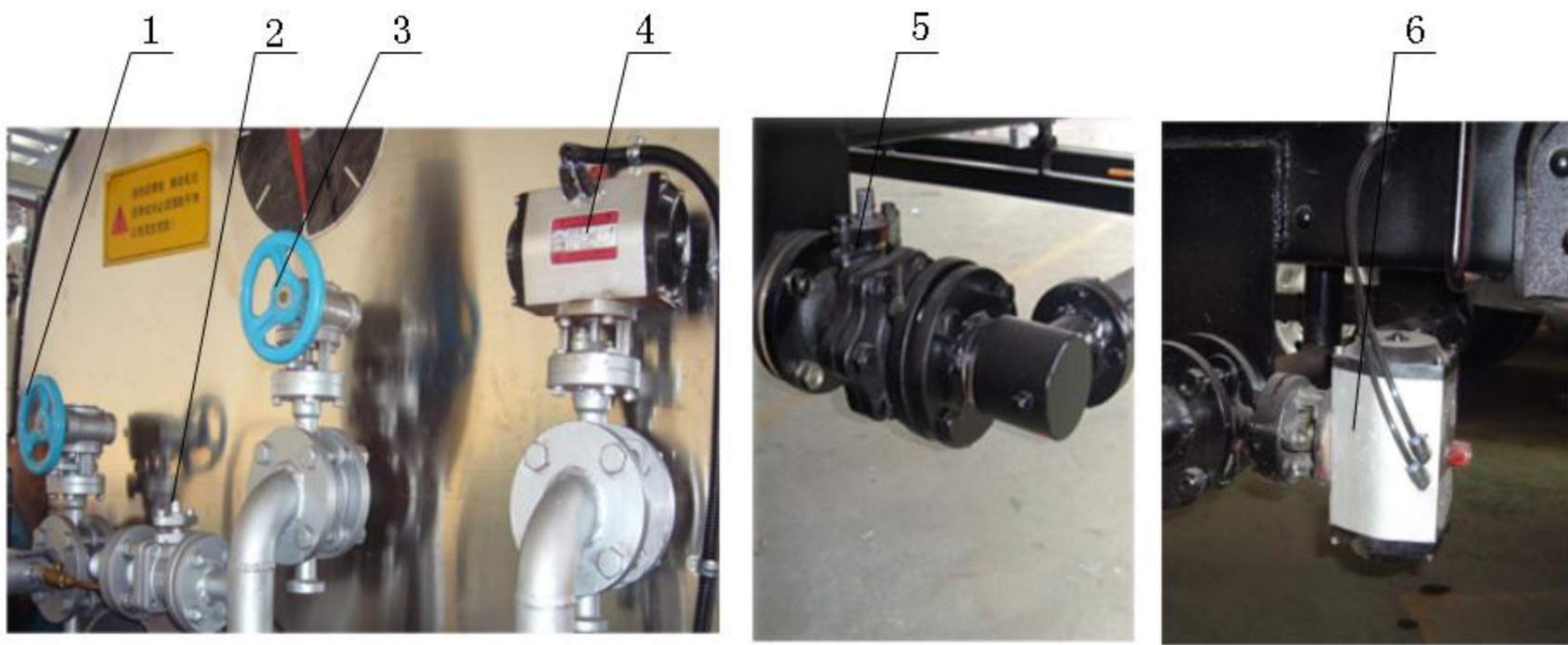

Fig. 11 Operation valve for spraying

1. Oil inlet valve    2. Handheld spray bar valve    3. Manual oil return valve    4. Pneumatic oil return valve
  5. Manual oil outlet valve (located at the lower left corner of the rear platform)    6. Pneumatic oil outlet valve (located at the lower right corner of the rear platform)
3. Start the truck engine and shift the gearbox to the low position (i.e. working position). If shifting cannot be achieved, shift the truck transmission to the 1<sup>st</sup> gear, and shift the gearbox again after appropriately driving the truck. Shift the truck transmission to the neutral position, shift the power take-off, and the hydraulic system will start operation.
  4. Turn on the power switch on the rear control platform (as shown in Fig. 9), turn on the asphalt valve switch, and turn on the asphalt pump switch. After that, the asphalt will circulate from the asphalt tank, via the oil inlet valve, filter, asphalt pump, manual oil outlet valve, left spray bar, middle spray bar, right spray bar and the pneumatic oil return valve, to the asphalt tank. It circulates for about 10 minutes until the spray bar and nozzle are heated to a higher temperature. Turn off the asphalt pump switch. Maintain the asphalt valve switch on, and close the rear console cover.
  5. Shift the truck transmission to a proper gear (that is determined according to the spray rate in the table below). Turn on the asphalt pump switch in the cab, drive the distributor truck to the point where spraying is to be started (generally 3 to 5 meters away), and turn on the spray switch to start asphalt spraying. Hold the engine speed at 1200~1500 rpm.



**Table**

**Spray rate reference (L/m<sup>2</sup>)**

| <b>Gear</b> | <b>Vehicle speed km/h<br/>(Engine speed at 1200 rpm)</b> | <b>Width 6m<br/>(using 13 nozzles)</b> | <b>Width 4.2m<br/>(using 9 nozzles)</b> | <b>Width 2.3m<br/>(using 5 nozzles)</b> |
|-------------|--|--|---|---|
| I           | 1.32   | 2.20                                   | 3.14                                    | 5.74                                    |
| II          | 2.23   | 1.29                                   | 1.84                                    | 3.36                                    |
| III         | 3.94   | 0.73                                   | 1.05                                    | 1.90                                    |
| IV          | 6.28   | 0.46                                   | 0.66                                    | 1.20                                    |
| V           | 10.89  | 0.26                                   | 0.42                                    | 0.67                                    |

- 6、 Drive the truck at a constant speed in a linear way while monitoring the actual spray rate through the spray rate display (as shown in Fig. 13). When reaching the point where spraying is stopped, turn off the spray switch, and then turn off the asphalt pump switch to end spraying operation.

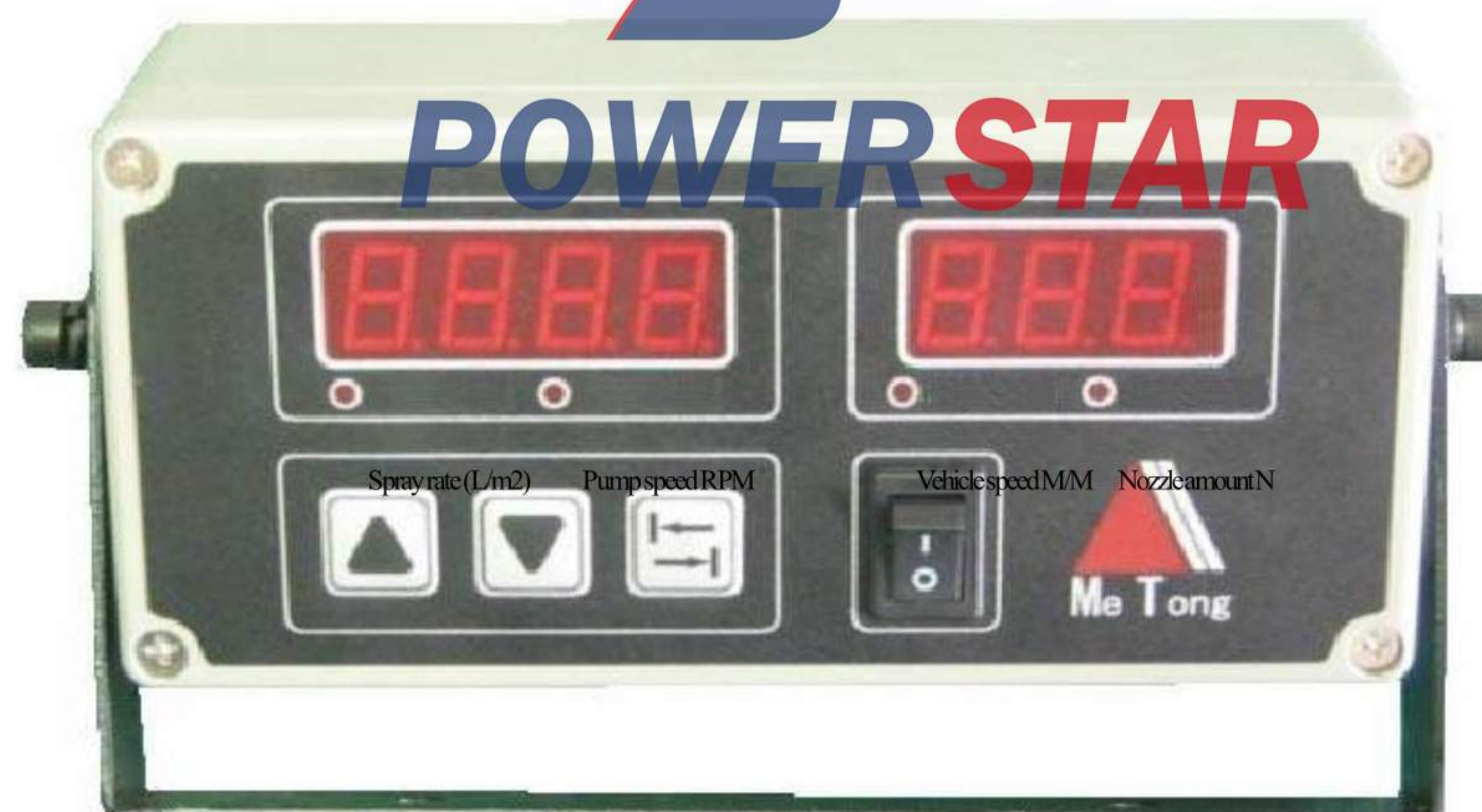

Fig. 12 Spray rate display

**Spraying via handheld spray bar:**

1. Connect the rubber hose and handheld spray bar to the handheld spray bar valve as shown in Fig. 13.
2. Open the oil inlet valve and the manual oil return valve 45°. Open the handheld spray bar valve. Close the manual oil outlet valve (located at the lower left corner of the rear platform) as shown in Fig. 11.
3. Start the truck engine, put the truck transmission to neutral position, engage the power take-off, and the hydraulic system will start to work.



- Turn on the power switch on the rear console (as shown in Fig. 9) and the asphalt pump switch. Ensure that the asphalt valve is closed before starting to spray asphalt via the handheld spray bar.

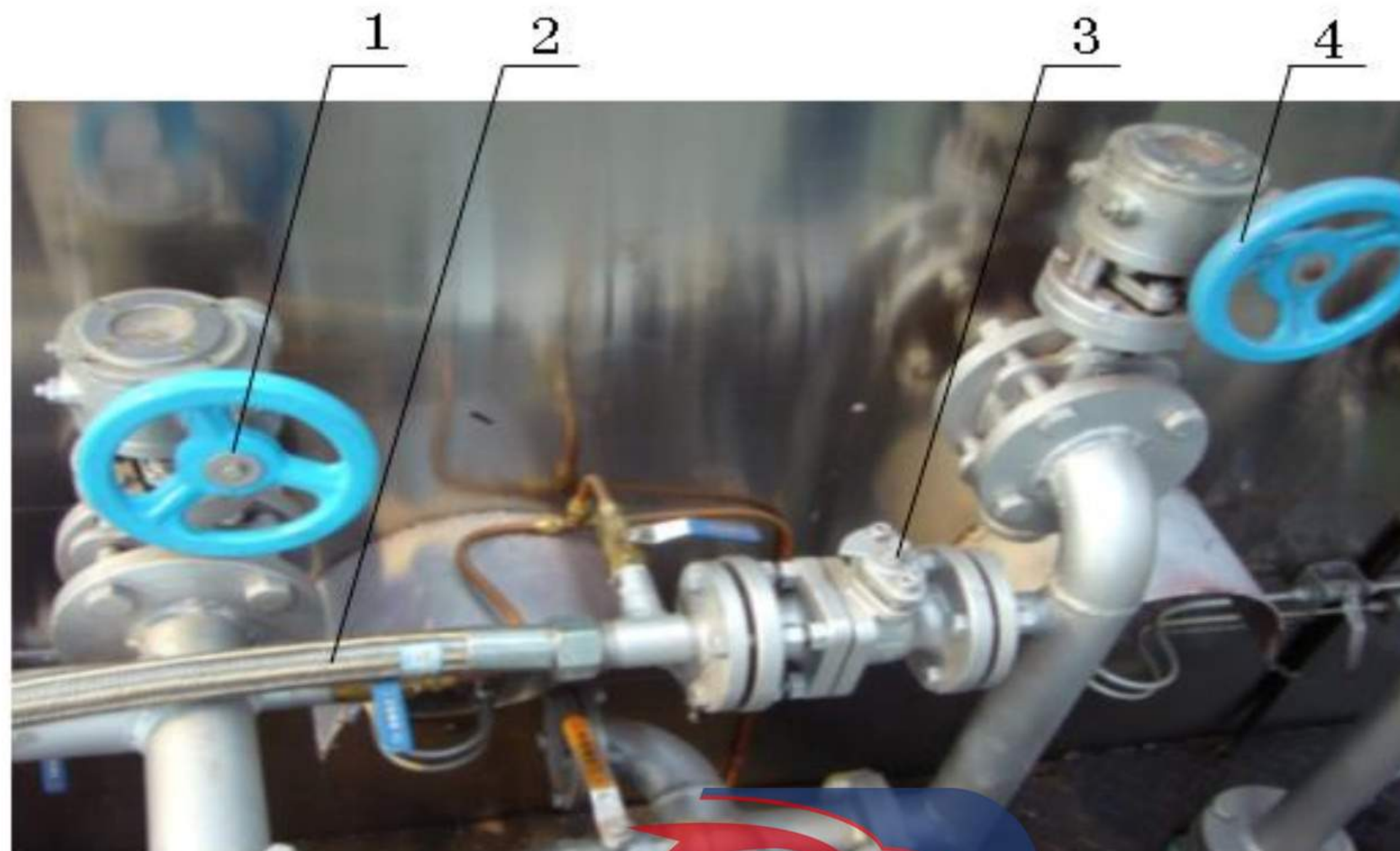

Fig. 13 Operation valve for handheld spray bar

1. Oil inlet valve   2. Rubber hose   3. Handheld spray bar valve   4. Manual oil return valve

- Adjust the angle of the oil return valve handle according to the atomization condition. Keep the engine running at 900~1000 rpm.

**⚠ Pay attention to the following when spraying the asphalt:**

- When spraying, never stand on the rear platform.
- When shifting the gearbox and power take-off, make sure to disengage the truck clutch; otherwise, the gear may be easy to be damaged.
- During spraying, drive the truck at a constant speed and do not suddenly depress the accelerator pedal.

## **(VI) Operation of Asphalt Pump and Pipe Cleaning**

Since asphalt will be solidified when the temperature is low, the filter, asphalt pump, pipes and nozzles shall be cleaned upon completion of operation or when the truck is transferred to another construction site. Otherwise, they cannot work next time. The cleaning methods are as follows:

### **After automatic spraying via rear spray bar:**

- Close the oil inlet valve, manual oil outlet valve (located at the lower left corner of the rear platform) and manual oil return valve (as shown in Fig. 11), and open the diesel inlet and out copper ball valves (as shown in Fig. 14). Turn on the power switch on the rear console (as shown in Fig. 9) and the asphalt pump switch. The asphalt valve switch shall be turned



off. Run the asphalt pump at a low speed for 2 to 3 minutes. Cleaning of the asphalt pump is finished.

2. Close the diesel inlet and outlet copper ball valves, and open the two manual oil outlet valves (located at the lower left platform). Turn off all nozzle switches, turn on the asphalt valve switch, and turn on the spray switch. Open the **main pipe air valve** (as shown in Fig. 14), and run the asphalt pump at a low speed. Open the oil drain valve on the rear spray bar, and flush off the asphalt remained in the pipe.

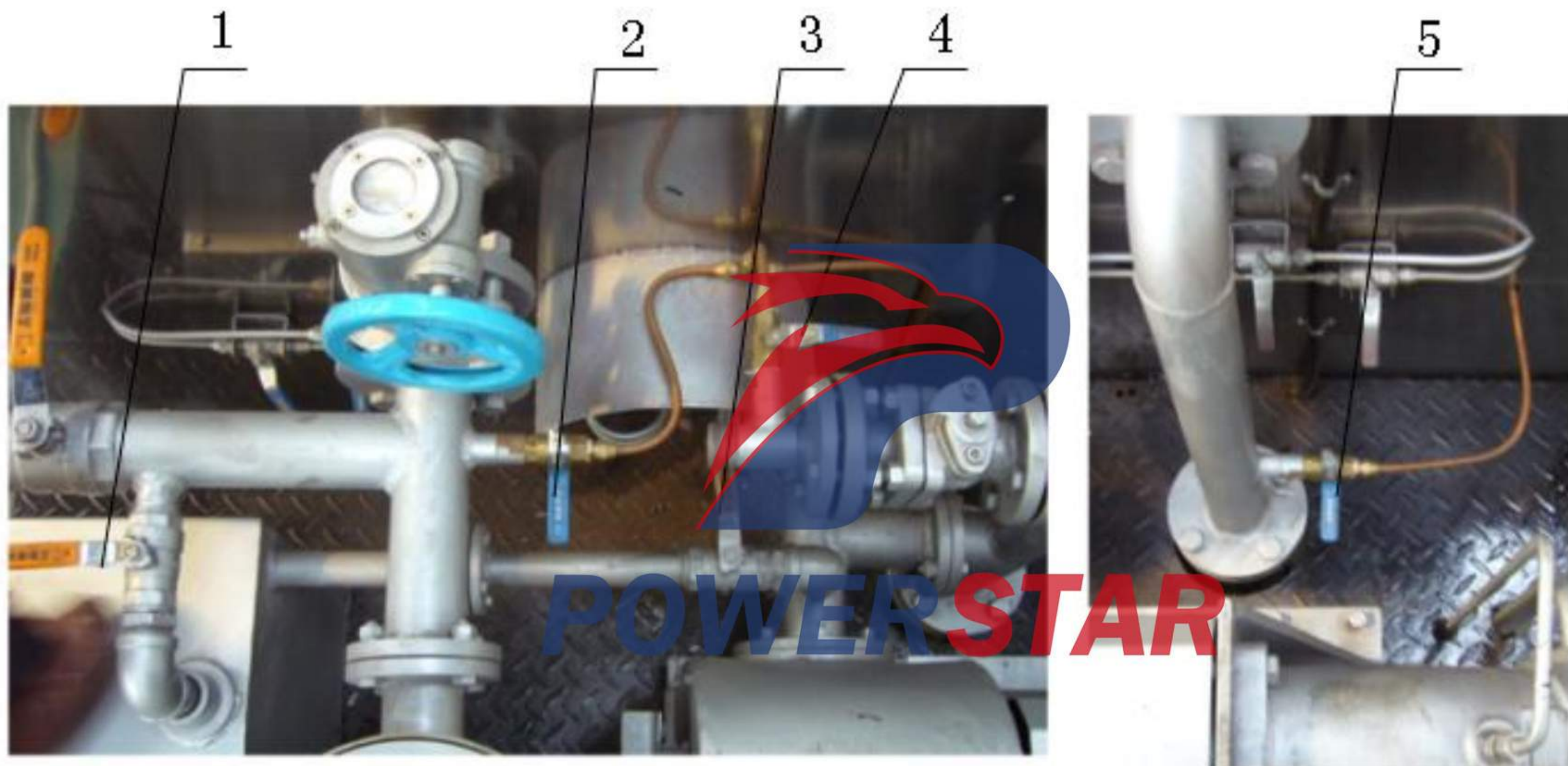

Fig. 14 Valves for cleaning the asphalt pump and pipes

1. Oil inlet copper ball valve    2. Main pipe air valve    3. Oil outlet copper ball valve    4. Air valve of handheld spray bar
5. Oil return pipe air valve

3. Close the **main pipe air valve**, and the oil drain valve on rear spray bar, and open the **oil return pipe air valve**. Turn on the nozzle switches one by one to flush the nozzle until air is found.
4. Close the **oil return pipe air valve**. Turn off all switches on the rear console and close the manual oil outlet valve (at the lower left corner of the rear platform). Stop the asphalt pump, open the oil drain valve under the filter to drain off the asphalt, and then close the oil drain valve.
5. Close all valves to finish cleaning.

**After spraying via handheld spray bar:**

1. The method for cleaning the asphalt pump is the same as above.



2. Keep the asphalt pump running, close the diesel inlet and outlet copper ball valves, open the **main pipe air valve** (as shown in Fig. 14), and open the manual oil return valve, in order to flush the asphalt remained in the oil return pipe into the tank.
3. Close the manual oil return valve and open the handheld spray bar valve to purge out the asphalt remained in the handheld spray bar. Stop the asphalt pump, open the oil drain valve under the filter to drain off the asphalt, and then close the oil drain valve.
4. Close the **main pipe air valve** to finish cleaning.
5. For spraying tasks via using the handheld spray bar with long interval between, the rubber hose and handheld spray bar shall be flushed. Close the handheld spray bar valve as shown in Fig. 14, and open the handheld spray bar air valve until air is blown out of the nozzle. At this time, the manual oil return valve shall be opened for about 45°.



**Pay attention to the following during pipe cleaning operation:**

1. During cleaning, the operators shall wear working clothes, gloves and protective helmets.
2. Cleaning must be done immediately **upon completion of spraying**; otherwise, the asphalt will be solidified and cannot be removed.
3. Upon completion of cleaning, make sure to close tightly the diesel inlet and outlet copper ball valves and the air valve.

## **(VII) Completion of Construction**

To ensure smooth operation in the next day, the following procedures must be fulfilled when the above-mentioned cleaning operation is finished.

1. Make sure to drain off the asphalt remained in the tank. If hot asphalt is firmly solidified at the tank bottom and will be very difficult to melt on the next day. For emulsified asphalt, deposits might be generated and severely clog the pump on the next day.
2. Open the asphalt filter cover, remove the strainer and put it into diesel for a thorough cleaning. Pour 2L diesel into the filter, put back the filter and tighten the cover. Apply high-temperature grease (#4 high-temperature grease or 7020 kiln bearing grease) at sealing positions for sealing and easy opening next time.
3. Check that all asphalt valves, diesel valves and air valves are closed.



### III. Technical Maintenance and Lubrication

#### (I) Running-in Maintenance of a New Truck

1. The running-in period for a new truck is 2500km trip distance or 60-hour operation.
2. For a new truck with a trip distance less than 2500 km, its chassis shall be subject to a running-in service at an authorized service station.
3. Service shall be carried out in exact accordance with the section “Running-in Period” in the User’s Manual.
4. Within running-in period, the distributor truck shall be driven at low speed and loaded below 60% of the rated load.
5. Daily check the bolt tightening of bolts on each part. Check each pipe connection for asphalt, fuel, hydraulic oil, compressed air and cooling water for any leakage or looseness.

#### (II) Technical Maintenance and Lubrication

During the service process, technical maintenance should be carried out for the distributor truck on schedule to ensure a failure-free operation of the machine and to maximize its service life.

Except the chassis, the distributor truck must be subjected to various levels of technical maintenance and lubrication in strict accordance with the User’s Manual. Besides that, regular maintenance and lubrication to each working system must be provided.

##### 1. Lubrication of power train:

After each 200-hour operation, drive shaft and pump transmission should be greased (with general lithium based grease for automobile according to GB/T5671-1995).

##### 2. Maintenance and lubrication of air compressor:

- a. Clean the air filter element after each 100-hour operation
- b. Check the oil level regularly. Immediately fill oil (air compressor oil L-DAA-46GB12691-1990) if the level is lower than the mark line.
- c. Check the V-belt and immediately replace it if it is worn out.

##### 3. Maintenance and lubrication of asphalt pump:

- a. Regularly check the input collar of the asphalt pump for oil leakage. Screw in the



compressing nut 1 to 2 rounds.

- b. At the end of each 100-hour operation period, apply 1 or 2 more sealing packings. During applying the sealing packing, apply high-temperature grease to the inner surface of the collars, sealing packings and hold-down nuts.
4. Maintenance of combustion system:
    - a. Clean the carbon deposit off the burner after each 100-hour operation.
    - b. Clean the fuel tank every 300 hours.
  5. Maintenance of hydraulic system:
    - a. Replace the hydraulic oil (with Great Wall 68# abrasion-resistant hydraulic oil) after the first 3-month (or 300-hour) operation. After that, replace the hydraulic oil and clean the hydraulic oil tank every year. The hydraulic oil that is not deteriorated can be reused after being filtrated it by using a filter less than 5 $\mu$ m.
    - b. After the first 3-month (or 300-hour) operation, the filter element for oil sucking and return oil shall be replaced. After that, they should be replaced yearly.
    - c. Check each pipe connection for any leakage, and replace the seal ring in time.
    - d. Check the hydraulic oil level regularly and refill it immediately when the level is below the mark line.
  6. Replacement of diesel in cleaning oil tank
    - a. Timely refill diesel into the cleaning oil tank.
    - b. Drain off the diesel from the cleaning oil tank every 2 to 3 days and clear off the asphalt deposited at the bottom of cleaning oil tank. Refill the drained diesel after it is sedimented and filtered.



## IV. Troubleshooting

The following table is for reference only. If you cannot judge the fault or remove it correctly, please consult our after-sales service department.

| No. | Fault   | Possible cause  | Solution  |
|-----|---|---|---|
| 1   | Power take-off can not be shifted.                    | <ol style="list-style-type: none"> <li>1、 Lack of pressure or air leakage from the exhaust pipe may exist.</li> <li>2、 An electrical switch may be damaged.</li> <li>3、 A solenoid valve may be damaged.</li> </ol>   | <ol style="list-style-type: none"> <li>1、 Check whether the air compressor or pressure regulating valve fails. In case of failure, replace the exhaust pipe.</li> <li>2、 Replace the switch.</li> <li>3、 Replace the solenoid valve.</li> </ol> |
| 2   | Gearbox can not be shifted.                           | <ol style="list-style-type: none"> <li>1、 Lack of pressure, or air leakage from the exhaust pipe may exist.</li> <li>2、 An electrical switch may be damaged.</li> <li>3、 A solenoid valve may be damaged.</li> <li>4、 The small cylinder may be damaged or the connection may come off.</li> <li>5、 The truck clutch may not disengage completely.</li> </ol> | <ol style="list-style-type: none"> <li>1、 Ditto.</li> <li>2、 Ditto.</li> <li>3、 Ditto.</li> <li>4、 Replace the small cylinder or securely fix the connection.</li> <li>5、 Adjust the truck clutch.</li> </ol>                                   |
| 3   | The asphalt pump does not work.                       | <ol style="list-style-type: none"> <li>1、 The hydraulic system may fail.</li> <li>2、 A blocking solid object may exist.</li> <li>3、 Seizing asphalt may exist.</li> </ol>   | <ol style="list-style-type: none"> <li>1、 Remove the hydraulic system failure.</li> <li>2、 Dismantle the asphalt pump to remove solids.</li> <li>3、 Wash the asphalt pump with diesel and bake the waste gas.</li> </ol>                        |
| 4   | The hydraulic motor does not run or run at low speed. | <ol style="list-style-type: none"> <li>1、 The overflow valve may be seized, or the pressure may be low.</li> <li>2、 The reversal valve coil may have no power or burnt out.</li> </ol>  | <ol style="list-style-type: none"> <li>1、 Dismantle and wash the overflow valve, and readjust the pressure.</li> <li>2、 Check the circuit or replace the coil.</li> <li>3、 Will be described in the column</li> </ol>                           |



| No. | Fault   | Possible cause   | Solution  |
|-----|---|--|---|
|     |   | 3、 The oil temperature may be excessively high, or there may be no pressure.<br>4、 The gear pump may be worn out.<br>5、 The hydraulic motor may be worn out.   | below.<br>4、 Replace the gear pump.<br>5、 Replace the hydraulic motor.  |
| 5   | The temperature of hydraulic oil is high (85°C or above).                 | 1、 The hydraulic oil is insufficient.<br>2、 There may be too much resistance to the asphalt pump, or oil leak from the overflow valve under high pressure for a long period.<br>3、 The oil suction filter may be blocked.                | 1、 Fill hydraulic oil.<br>2、 Check the asphalt pump and the overflow valve.<br>3、 Clean the filter.   |
| 6   | The burner can not be ignited.  | 1、 Bad fuel may be used.<br>2、 The fuel tank may be soiled, or the fuel pipe may be clogged.<br>3、 Carbon deposit or blockage of burner may exist.<br>4、 The air pressure may be too low (<0.4 MPa).                                     | 1、 Replace the fuel.<br>2、 Clean the fuel tank or purge the fuel pipe with compressed air.<br>3、 Dismantle and wash the burner.<br>4、 Will be described in the column below |
| 7   | The pressure of compressed air rises too slowly, and the pressure is low. | 1、 The air compressor may not run.<br>2、 The belt of the air compressor may be excessively loose.<br>3、 The valve seat of the air compressor may be loose, or the valve disc may be blocked or damaged.<br>4、 The pressure regulator may | 1、 Check the electromagnetic clutch.<br>2、 Adjust the belt tension.<br>3、 Adjust or replace it.<br>4、 Adjust or replace it.<br>5、 Tighten or repair the connection.         |



| No. | Fault   | Possible cause   | Solution   |
|-----|---|--|--|
|     |   | fail.<br><br>5、 The air reservoir or connection may have a leakage.  |  |
| 8   | The asphalt pump works normally, but sprays no asphalt. | 1、 The asphalt valve may be placed at a wrong position.<br>2、 The suction oil inlet may be blocked by asphalt.<br>3、 The asphalt filter may be blocked.<br>4、 The oil outlet pipe may be blocked by asphalt.   | 1、 Adjust the valve position by following the instructions described in Section 1, (V), III.<br>2、 If hot asphalt is used, wait for self melting. For use of emulsified asphalt, bake or dredge the oil suction port after draining the asphalt.<br>3、 Take out and wash it.<br>4、 Bake or dredge the oil outlet pipe. |
| 9   | The spray pressure is insufficient or intermittent.     | The asphalt filter strainer may be blocked.<br>Filter cover may have a air leakage.<br><br>The main pipe air valve may be not closed tightly.<br><br>The temperature of asphalt may be too low.<br><br>The oil return valve (on top of the tank) may be not closed.<br><br>The asphalt pump may be worn out.<br><br>Operation of hydraulic system may be not stable. | Remove the trouble.<br><br>Tightly seal and cover.<br><br>Close the valve tightly.<br><br>Heat asphalt to the designated temperature<br><br>Place the oil return valve to the proper position.<br><br>Repair or replace the asphalt pump.<br><br>Check the hydraulic system.   |
| 10  | Asphalt is not sprayed evenly.                          | The spray pressure may be insufficient.<br><br>The nozzle may be blocked by foreign matters.   | Check and adjust as the above mentioned.<br><br>Remove the foreign matters.  |
| 11  | Asphalt can not be sucked for self-suction.             | The oil inlet valve may be not closed securely, or the oil return valve (on top of the tank) may be not opened.  | 1、 Check the valve.<br>2、 Tightly seal and cover.  |



| No. | Fault | Possible cause   | Solution   |
|-----|-------|--|--|
|     |       | 2、 The filter cap may have an air leakage.<br>3、 The main pipe air valve may be not closed tightly.<br>4、 The temperature of asphalt is may be too low.<br>5、 The truck may be too far away or too close to the asphalt storage tank.<br>The asphalt pump may be worn out. | 3、 Close it tightly.<br>4、 Heat asphalt to the designated temperature.<br>5、 Change the condition; otherwise, do not start self-suction.<br>6、 Repair or replace the asphalt pump. |

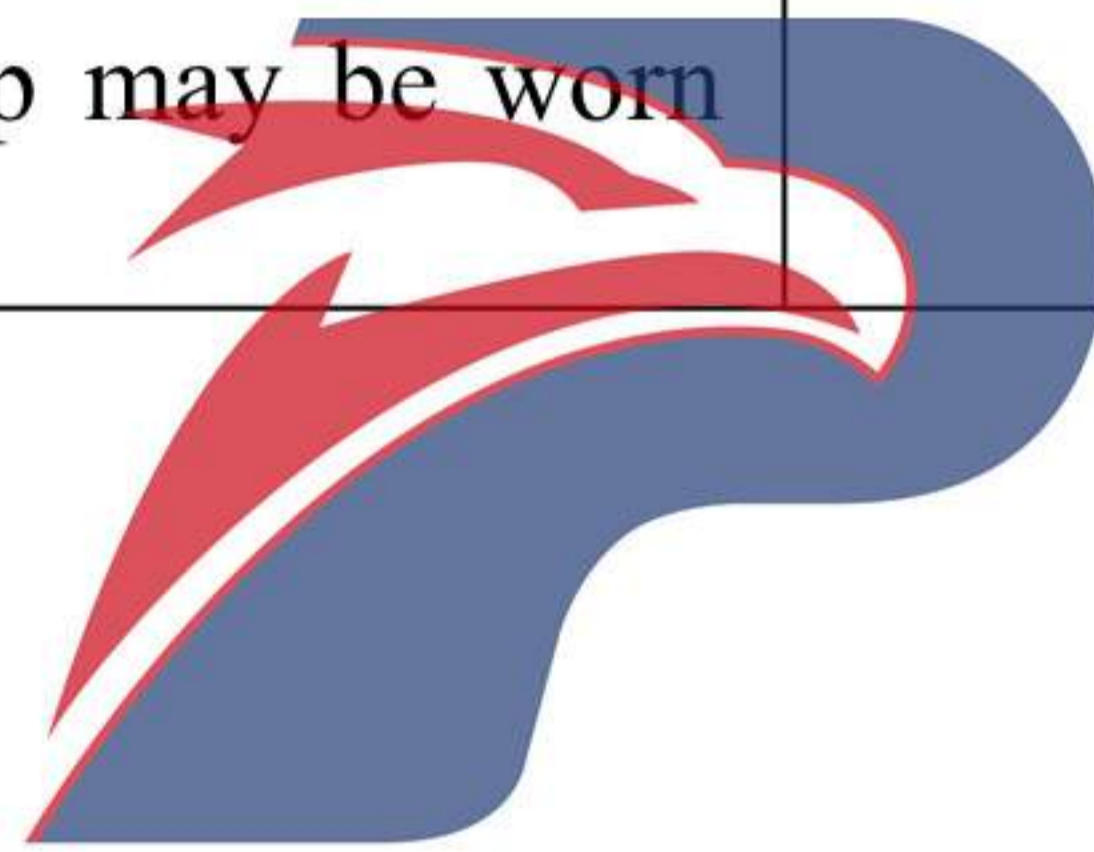

**POWERSTAR**